

Effect of Pulsed Electric Field Pre-Treatment on Thai Mango Pickle Production

Supakiat Supasin¹, Chatchawan Kantala², Panich Intra², Phadungsak Rattanadecho^{1,*}

¹*Department of Mechanical Engineering, Faculty of Engineering,
Thammasat University, Pathum Thani 12120, Thailand*

²*Research Unit of Applied Electric Field in Engineering, College of Integrated Science and
Technology, Rajamangala University of Technology Lanna, Chiang Mai 50300, Thailand*

Received 20 April 2022; Received in revised form 1 July 2022
Accepted 5 July 2022; Available online 20 March 2023

ABSTRACT

This study aimed to investigate the influence of a pulsed electric field (PEF) and compote process on Thai mango pickle production. A factorial completely randomized design (CRD) was conducted at electric field strengths of 2 and 3 kV/cm, electrical frequencies of 1 and 3 Hz, and 700 and 1,300 pulses. The PEF experiments were done in 50 °Brix sucrose syrup for 30 h at 30 °C in comparison with a conventional method. The moisture content, water activity (a_w), colour, texture properties, mass transfer, and microstructure of pickled mango were investigated. Water loss (WL), solid gain (SD), and water reduction (WR) of PEF-pickled mangos increased approximately 2.5-3 fold as compared to the control. The combination of PEF and compote processes significantly reduced moisture content, a_w , colour, and texture in terms of hardness and toughness ($p < 0.05$). Among eight treatments, the application of a PEF at 3 kV/cm field strength, 1 Hz of frequency, and 1,300 pulses provided the highest value of mass transfer. The microstructure of mangos after the PEF processes was disintegrated and of uncertain structure. This finding implies that the combination of a PEF and compote process might be an effective pickling process for pickling mangoes on an industrial scale due to quickening of the mass transfer rate.

Keywords: Electric frequency; Electric field strengths; Mango pickle; Pulsed electric field; Pulse number

1. Introduction

Mango is considered an important economic crop of Thailand. Different varieties of this fruit are abundant in almost all areas of Thailand. Fresh and pickled mangoes are exported to various countries where they can be processed into many other product types. Most Thai people like to consume mangoes in various forms. Therefore, its cultivation is popular. Mango plants are easy to care for. The data recorded for the production of mangoes show a significant increase in revenue each year [1]. There are several agricultural and industrial production processes for mangoes [1]. Industrial applications have been focused on increasing productivity while reducing production costs. In addition, more consumers have been demanding safe, healthy, and eco-friendly food products [2].

Fruit compote is a food processing technique to reduce or limit the water content in food matrices that can be used by microorganisms. Sucrose solution is introduced into the fruit tissues to provide sweetness and to increase the sucrose concentration until the fruit tissues reach their saturation point [3]. The variation in osmotic force causes a mass transfer of water from the fruit tissue into the surrounding environment resulting in diffusion of sucrose into the fruit tissues [4]. The processed food industry currently uses heat to help in the saccharification process. Heat speeds up the pickling process by weakening and opening the tissues of the fruit, resulting in better and faster mass transfer. However, a high temperature is used and it takes a long time to change some of the structures of the fruit, so the tissue is severely damaged. As a result, the processed fruit has a dull texture, darker colour, burnt brown smell and loses its nutritional value [5].

Currently, there are research reports that apply a pulsed electric field (PEF)

system for pre-treatment of raw materials such as pickled mango before pickling [6]. Pre-treatment with PEF does not use heat in the pre-saccharification process [7]. A high-intensity PEF sends a high voltage charge over the cell or membrane, causing the process of electroporation and complete cell destruction. As a result, the cellular structure and cell membranes are permanently destroyed [8] which causes a large number of pores in the cell area. These pores provide channels for the removal of water from cells at high osmotic rates [9], resulting in greater diffusion of the sucrose solution into the tissues, thus increasing both the solids content and the amount of water lost [10].

However, the combination of PEF and compote process has not been thoroughly investigated. Therefore, this research aimed to use mango as a fruit model to apply a PEF process in combination with a compote process. This study compared a PEF-combined compote process with 50°Brix sucrose syrup for 30 h at 30°C with a conventional method. Moisture content, water activity (a_w), colour, texture properties, mass transfer (water loss (WL), solid gain (SD), water reduction (WR), and microstructure were analysed. The information from this research might enhance the quality of Thai mango pickles.

2. Materials and Methods

2.1 Mango preparation

Thai mango (*Mangifera indica*, Anacardiaceae) variety ‘Choke Anan’ was collected from farms located in the north of Thailand and kept in the open air until the samples were prepared. Before processing, the fruit was washed by hand and the flesh cut into 2×4×0.5 cm (width×length×height) rectangles weighing 10±1 g. All the mangoes used for the experiment were from the same set.

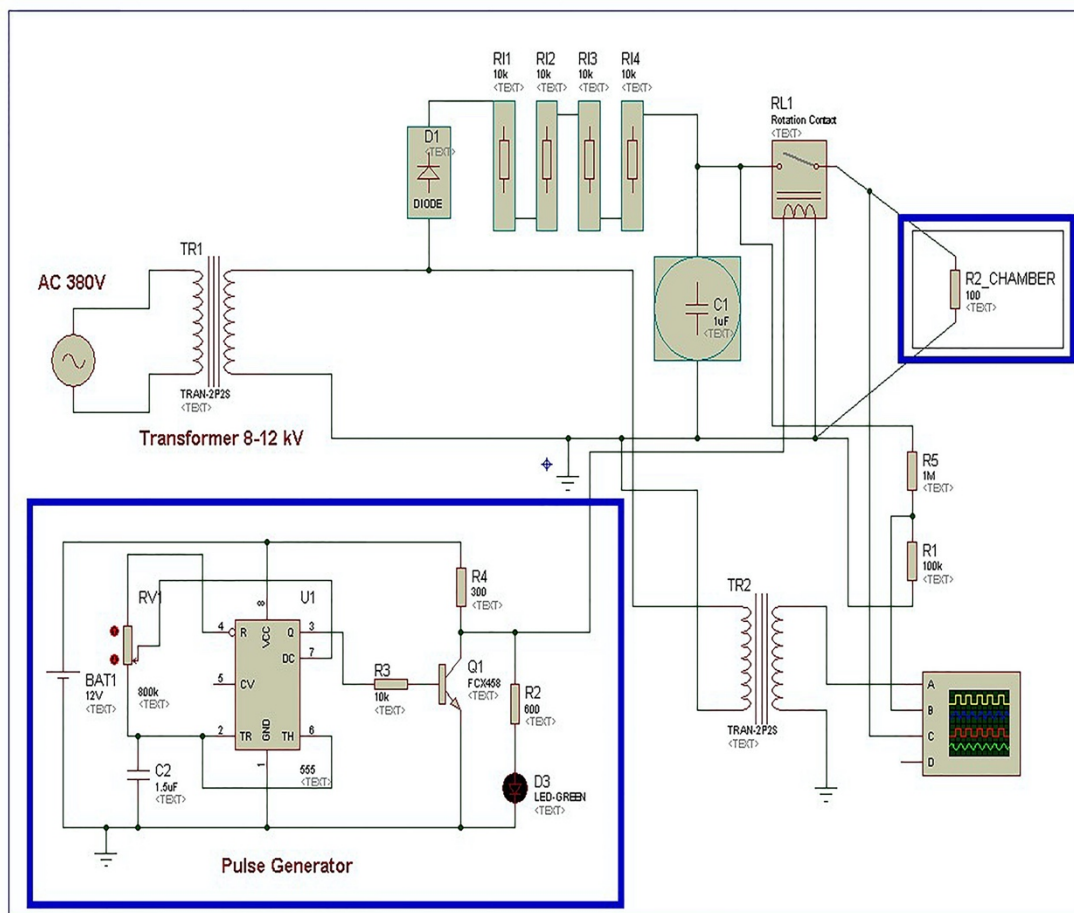

Fig. 1. Circuit diagram of the pulsed electric field system for pickled mango processing.

2.2 Pulsed electric field (PEF) treatment

The mango samples were immersed in 50% (w/w) hypertonic solutions of sucrose syrup before being treated with the PEF system. The PEF system was developed by the Electrical Field Research Unit (Rajamangala University of Technology Lanna, Thailand). It is 900×140×180 cm (width×length×height) in size; the chamber is made from 316 L stainless steel and Teflon (PTFE) and has a capacity of 5L (size 37.5×4×45 cm, L×W×H) with 4 cm of gap electrode. The diagram for the PEF system used in this study is shown in Fig. 1. A completely randomized design (CRD) was performed to analyse the combination effect of the electrical field strength at 2 and 3 kV/cm, pulse frequency at 1 and 3 Hz, and number

of pulses at 700 and 1,300 pulses on quality changes of Thai mango after osmosis for 30 h; the experimental design is shown in Table 1. All experiments were repeated three times.

2.3 Microstructure of mango surface

The changes of mango microstructure and surfaces were evaluated by a scanning electron microscope (SEM; Prima™ E, Thermo Scientific, Waltham, MA, USA). The mango was sliced into 0.5 mm pieces before being placed on stubs. The accelerating voltage of the SEM was 15 kV.

Table 1. Experimental design: factorial CRD with scanning electron microscope.

Treatment	Condition		
	Intensity (I)	Frequency (F)	Number of pulse (Np)
1	2	1	700
2	2	1	1300
3	2	3	700
4	2	3	1300
5	3	1	700
6	3	1	1300
7	3	3	700
8	3	3	1300
Control	0	0	0

2.4 Mass transfer phenomena

The mass transfer of mango pickles was evaluated through water loss (WL) (g water/g initial dry matter), solids gain (SG) (g total solids/g initial dry matter) and weight reduction (WR) according to Eqs. (2.1)-(2.3):

$$WL = \frac{(M_0 - W_0) - (M - m)}{m_0}, \quad (2.1)$$

$$SG = \frac{(m - m_0)}{m_0}, \quad (2.2)$$

$$WR = \frac{(W_0 - W_t)}{W_0}, \quad (2.3)$$

where M_0 is the initial mango mass before treatment, W_0 is the weight of fresh mango (g), M is the mango mass after 30 h of processing, m is the dry mango mass after 30 h, m_0 is the dry mango mass before processing [11], and W_t is the weight (g) after 30 h [12].

2.5 Quality determination

2.5.1 Moisture content

The moisture content of fresh mangoes and PEF pre-treated mangoes was analysed by hot air oven [13]. The mangoes were dried at 105°C for 3 h, put into a freezer in a desiccant jar to reduce the moisture, and then brought to room temperature. The mango (W_1) and mango sample (W_2) were then weighed, put into a moisture can and baked at 105°C overnight.

They were removed from the incubator and put it into a desiccant jar and left until the temperature of the moisture can was reduced to room temperature. The can was then weighed with the sample (W_3). For each collection, three iterations were performed, the average value calculated, and the result reported in units of the wet standard percentage (%wb), calculated using Eq. (2.4).

$$\text{Moisture (\%)} = \frac{W_2 - (W_3 - W_1)}{W_2}. \quad (2.4)$$

2.5.2 Water activity (a_w)

The change of a_w of fresh mangoes and mangoes processed with PEF is important for shelf life and food safety. The a_w value was collected in each of the experiments; three repetitions were performed using an Aqualab CX3TE meter (USA).

2.5.3 Colour

The mangoes' change in colour was measured using a spectrophotometer (MiniScan EZ 4500L, Hunter Associates Laboratory, USA), in CIE L* a* b* scale mode. The measurement was taken in five repetitions with randomly selected mangoes and total colour change values were evaluated according to Eq. (2.5).

$$\Delta E = \sqrt{(L - L_0)^2 + (a - a_0)^2 + (b - b_0)^2}. \quad (2.5)$$

2.5.4 Texture analysis

The TA.XT Plus texture analyser (Stable Micro Systems Ltd, UK) was used to measure hardness and toughness of the mangoes. The conditions, including compression force, return to start, pre-test, test and post-test speed, were set at 1.5 mm/s, 1.5 mm/s, 10.0 mm/s, respectively. The distance between probe and sample was 5 mm. Ten iterations of each example were

analysed to show that the resulting value was certain.

2.6 Statistical analysis

All experimental data were presented as mean \pm standard derivation. One-way analysis of variance (ANOVA) with significance levels of 95% and comparison by Duncan's test was used to investigate the difference of the samples (SPSS Version 23, IBM, USA).

3. Results and Discussion

3.1 Change of WL, SG, and WR

The change of WL and SG of mango after PEF-assisted compote process is shown in Figs. 2 and 3, respectively. After being treated with PEF and pickled in sucrose syrup (50 °brix) for 30 h, it was found that WL and SG gradually increased and depended on the PEF process

conditions. The use of PEF increased the WL and SG values more than the non-PEF treated samples. This might be due to the mass transfer mechanism [14]. PEF conditions of 3 kV/cm intensity, 1 Hz frequency and 1,300 pulses gave the highest WL value, followed by treatment at 2 kV/cm, 1 Hz and 1,300 pulses, with WL values of 2.84 ± 0.22 and 2.66 ± 0.09 g/g, respectively. PEF conditions of 3 kV/cm, 1 Hz and 1,300 pulses gave the highest SG, followed by treatment at 2 kV/cm, 1 Hz and 1,300 pulses, with SG values of 0.29 ± 0.02 and 0.27 ± 0.01 g/g, respectively. Non-treated samples had less WL and SG than PEF-treated ones, with WL of 1.29 ± 0.07 g/g and SG of 0.13 ± 0.01 g/g. Therefore, it can be said that the WL and SG increased after mangoes were treated with PEF (Figs. 2 and 3), when compared to the untreated mango.

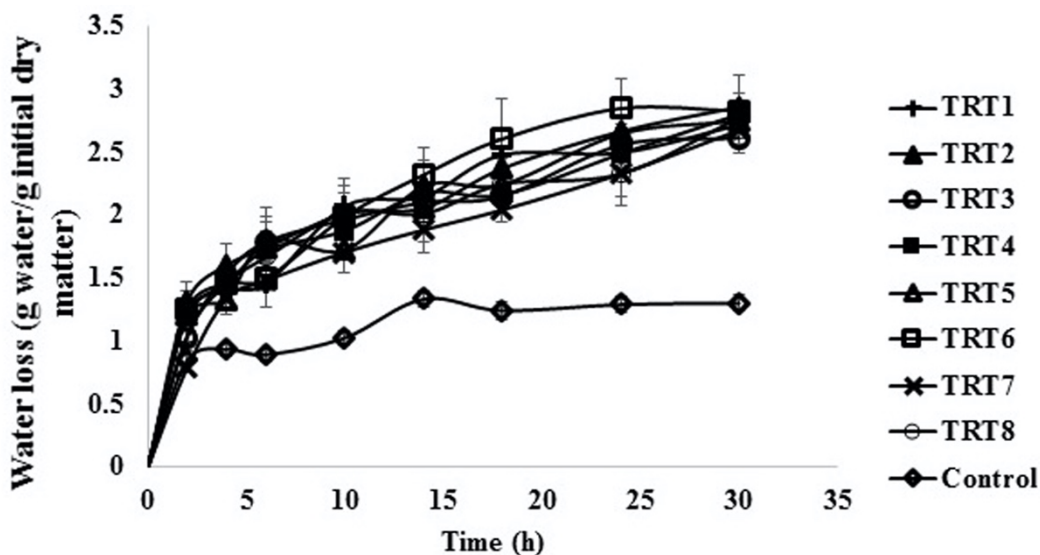

Fig. 2. The time cause of the water loss of PEF pre-treated mango in 50 °brix sucrose solution in comparison with non-treatment processes.

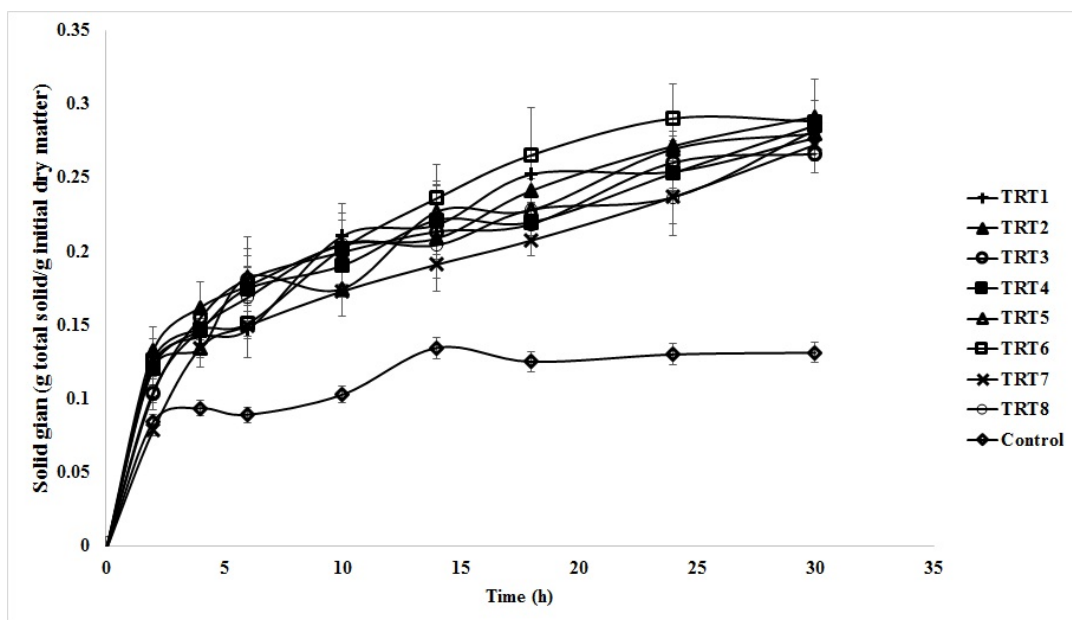

Fig. 3. The time cause of the solid gain of PEF pre-treated mango in 50 °brix sucrose solution in comparison with non-treatment processes.

Tedjo et al. [6] found that mango slices treated with 2.67 kV/cm and 100 pulses before immersion in 50 °brix sucrose syrup had more WL and SG than those subjected to the conventional mango pickling process at 5 h, because cell walls and cytoplasm were destroyed by PEF, resulting in rupture and porosity of a large number of cells or membranes [7]. Some of the water in the mango was released into the solution, increasing the value of WL and SG. This might be due to the effect of PEF on cell tissue structures [8], which agrees with the work of Traffano-Schiffo et al. [15].

Fig. 4 shows that there was a significant reduction in the weight of mangoes at 0-2 h. Mangoes treated with PEF had significantly higher WR than controls. The WR of the control was 1.16 ± 0.06 g/g, which was lower than that of the mango treated by PEF. PEF conditions of 3 kV/cm, 1 Hz and 1,300 pulses gave the highest WR, followed by treatments at 2 kV/cm, 1 Hz and 1,300 pulses, with WR values of 2.55 ± 0.20 and 2.39 ± 0.08 g/g, respectively. PEF-treated mangoes had a greater reduction in weight than controls

due to the OD process, which was accelerated after PEF treatment due to cell membrane destruction, thus increasing membrane permeability [16]. Some authors have reported that PEF leads to vacuole shrinkage and damage to the tonoplast, resulting in increased water content of both the cytoplasm and extracellular space [17]. In addition, the high-intensity of PEF leads to damage of the cell membrane by pore formation. This results in improved mass transfer and diffusion coefficients [18]. Therefore, it was observed that the WL, SG and WR of mangoes increased due to the irreversible membrane pore formation after PEF processing [8]. As a result, a large amount of water in the mango was dislodged. Therefore, mangoes treated with PEF lost more weight than controls, thus reducing production time.

From this finding it can be concluded that this Thai made PEF-machine prototype is more effective at processing compote mango and achieves a higher mass transfer mechanism compared to PEF machines manufactured in other countries.

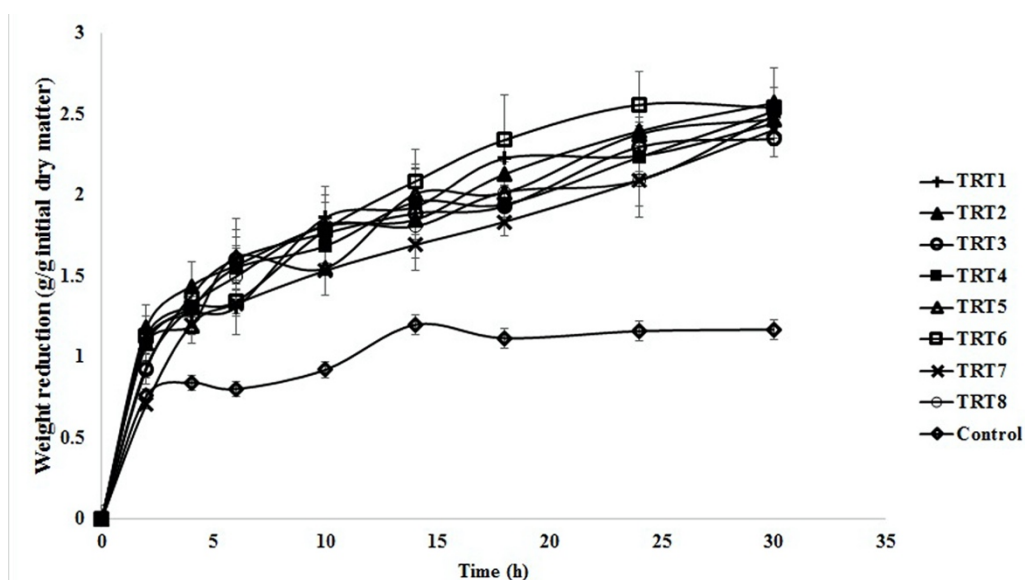

Fig. 4. The time cause of the weight reduction of PEF pre-treated mango in 50 °brix sucrose solution in comparison with non-treatment processes.

3.2 Moisture content and water activity

The moisture content of mango after osmosis in 50 °Brix sucrose solution for 30 h is shown in Fig. 5. The moisture content of fresh mango at the starting point was 90.67 ± 0.96 %wb and decreased significantly as time increased. All PEF-treated samples had a lower moisture content than that of the control sample, in the range of 62.69–68.38% compared to 77.35%, respectively (Table 2). The water in the mango cells spreads out of the cells into the sucrose solution, as the solute or sugar diffuses into the mango cells through a semipermeable membrane. Osmotic

pressure creates a driving force between the osmotic solution and mango cells, which causes the mass transfer of the water and solids [5]. The mass transfer during intracellular osmosis of mangoes, particularly the diffusion of water and sucrose, reduced the samples' moisture content [19]. This corresponds to the increased WL and SG values in samples treated with PEF.

The a_w of fresh mango was 0.98 ± 0.003 , reduced to 0.94-0.96 after 30 h of osmosis (Table 2). PEF-treated samples had lower a_w than controls.

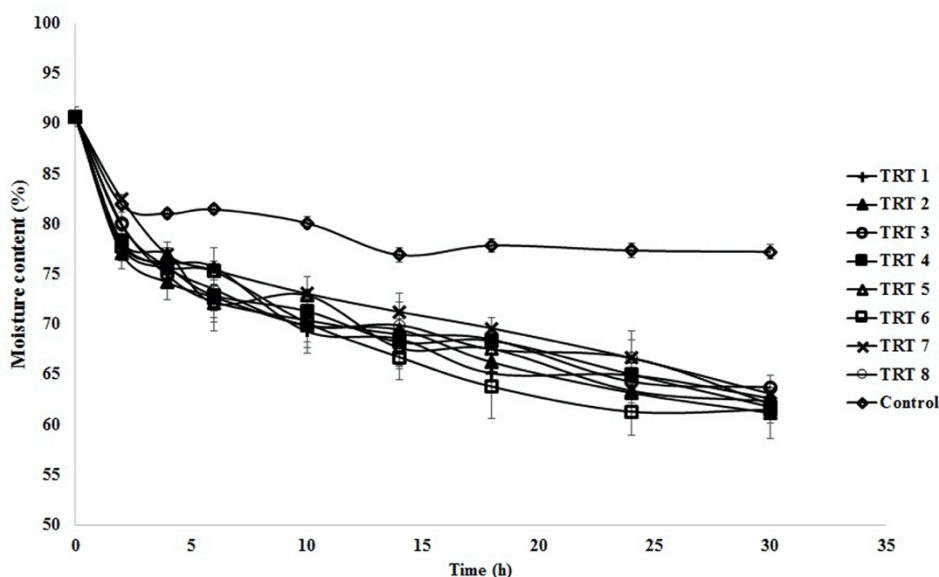

Fig. 5. The time cause of the moisture content of PEF pre-treated mango in 50 °brix sucrose solution in comparison with non-treatment processes.

Table 2. Mean value of the physical properties and colour of each experimental sample.

Treatment	MC (%wb)	a_w	Colour			
			L^*	a^*	b^*	ΔE
1	62.69±1.76 ^c	0.95 ± 0.002 ^d	55.49 ± 2.81 ^b	-0.36 ± 0.15 ^a	25.79 ± 6.08 ^b	22.64±2.85 ^b
2	63.17±1.01 ^e	0.94 ± 0.003 ^c	53.98 ± 1.52 ^{bc}	-0.22 ± 0.25 ^a	27.12 ± 1.35 ^b	23.45±1.45 ^{ab}
3	64.29±1.78 ^c	0.95 ± 0.004 ^{cd}	50.93 ± 1.38 ^{cd}	-0.26 ± 0.06 ^a	26.99 ± 3.04 ^b	26.58±1.54 ^{ab}
4	65.01±1.22 ^{dc}	0.95 ± 0.003 ^{cd}	54.72 ± 2.17 ^{bc}	-0.21 ± 0.12 ^a	29.82 ± 2.25 ^b	22.66±2.12 ^b
5	63.17±1.14 ^c	0.95 ± 0.007 ^{cd}	50.09 ± 3.25 ^d	-0.47 ± 0.08 ^a	25.05 ± 1.33 ^b	27.54±3.38 ^a
6	63.39±1.73 ^c	0.95 ± 0.004 ^{cd}	52.64 ± 3.38 ^{bcd}	-0.16 ± 0.08 ^a	28.17 ± 2.39 ^b	24.75±3.49 ^{ab}
7	68.38±1.46 ^c	0.95 ± 0.005 ^{cd}	54.89 ± 0.78 ^b	-0.17 ± 0.13 ^a	27.95 ± 2.02 ^b	22.51±0.85 ^b
8	66.65±0.07 ^{cd}	0.96 ± 0.002 ^c	52.93 ± 1.68 ^{bcd}	-0.23 ± 0.17 ^a	27.12 ± 2.51 ^b	24.55±1.87 ^{ab}
Control	77.35±0.71 ^b	0.96 ± 0.003 ^b	55.77 ± 0.51 ^b	-3.49 ± 0.06 ^b	35.48 ± 0.36 ^a	22.60±0.39 ^b
Raw	90.67±0.96 ^a	0.98 ± 0.003 ^a	77.30 ± 0.31 ^a	-0.46 ± 0.39 ^a	29.30 ± 4.16 ^b	3.05±1.89 ^c

Means ± standard deviation followed by different letters in the same column are significantly different ($p < 0.05$).

PEF conditions of 2 kV/cm, 1 Hz and 1,300 pulses gave the lowest a_w (0.94 ± 0.003). The values of a_w correspond to change in the cellular structure of fruit tissues; this might affect the movement and dispersion of water within cellular tissues [20-22].

3.3 Colour

Colour is a physical property of food that affects its quality and consumer acceptance. The colour of food tends to change easily during food processing, but

osmosis is a mild transformation, which contributes to better preservation of colour compared to heat treatment [15]. The Thai mango variety 'Choke Anan' is green and white. In this study, the fresh mango had the L^* value of 77.30 ± 0.31 (Table 2). The application of PEF resulted in an L^* range of 55.49 to 50.09, which is not significantly different from untreated mango pickles (55.77 ± 0.51). This agrees with the results of Tylewicz et al. [22], who found no change in the L^* of strawberry samples which

underwent the OD process after PEF treatment. Furthermore, the mango treated with PEF also showed no significant difference of a^* and b^* from fresh mango ($p \leq 0.05$). However, the normal pickling process (control) increased a^* but decreased b^* compared to fresh mango. The reason for this may be that the PEF-treated samples had less enzymatic browning than the control sample. Tylewicz et al. [23] suggested that the high-intensity of PEF can inhibit the activity of peroxidase and polyphenol oxidase. PEF also increases osmosis or improves solute uptake. This results in reduced O_2 transfer to the surface, reducing the enzymatic browning reaction [16].

3.4 Hardness and toughness

The hardness and toughness of fresh mango were 54.17 ± 3.63 N and 85.23 ± 1.78 mJ/m³, respectively. However, after the PEF-assisted compote process in sucrose syrup for 30 h, the hardness and toughness of the mangoes significantly decreased from 51.77 ± 8.55 to 8.80 ± 0.12 – 33.10 ± 1.90 N and from 46.73 ± 1.60 to 8.29 ± 0.29 – 16.07 ± 0.48 mJ/m³, respectively, compared with the non-PEF process (Table 3). The application of PEF at 3 kV/cm, 3 Hz and 1,300 pulses gave the lowest hardness and toughness values of 8.80 ± 0.12 N and 8.29 ± 0.29 mJ/m³, respectively. This is consistent with the report of Fincan and Dejmek [24], which found that onion cells can be destroyed by 0.33 kV/cm, as well as the report of Chiralt and Talens [25] who reported that PEF increases pore formation resulting in a soft structure [14]. In addition, hardness and toughness are reduced by increasing plasmolysis, vacuole contraction and changes in the cell wall structure caused by the OD process [21].

3.5 Effect of PEF on cell membrane permeabilization

The cell walls of the samples were studied using an SEM as shown in Fig. 6.

The samples treated with PEF had larger pores than those of the control group because the PEF was able to damage cell membranes, causing greater porosity in the mango tissue [26].

Table 3. Experimental design: factorial CRD with scanning electron microscope.

Treatment	Hardness (N)	Toughness (mJ/m ³)
1	33.10 ± 1.90^b	16.07 ± 0.48^c
2	20.61 ± 2.01^c	13.34 ± 0.81^d
3	20.83 ± 0.26^c	13.04 ± 0.20^d
4	18.53 ± 2.00^c	12.94 ± 0.30^d
5	15.83 ± 3.12^c	11.99 ± 0.67^d
6	16.73 ± 1.07^c	12.20 ± 0.37^d
7	15.83 ± 3.12^c	11.66 ± 0.69^d
8	8.80 ± 0.12^d	8.29 ± 0.29^e
Control	51.77 ± 8.55^a	46.73 ± 1.60^b
Raw	54.17 ± 3.63^a	85.23 ± 1.78^a

Means \pm standard deviation followed by different letters in the same column are significantly different ($p < 0.05$).

The increase of frequency and number of pulses significantly increased the pore numbers. A study by Thamkaew and Galindo [27] also reported that the increased PEF intensity leads to an increase in the nuclei in plant tissues, while electrophoresis of the cell membrane increases as the pulse number increases. The cavities of the top surface were larger than those of the side surface. Barański et al. [2] revealed that the pulsed intensity and pulse number of PEF affects mango tissue by causing irreversible damage to cell viability [22] and changes of the cell network resulting in gaps between cells [6]. The increased number of gaps or pores within the cell results in better mass transfer during osmosis [28].

4. Conclusion

The combination of PEF and compote processes is an effective process for increasing mass transfer mechanisms and reducing moisture content and water activity of Thai pickled mango with 50 °Brix sucrose syrup. The most preferable PEF combined compote condition for pickling mango with 50 °Brix was an intensity of 3 kV/cm, frequency of 1 Hz and

1,300 pulses, which increased the mechanisms of the mass transfer by 2.5-3.0 times. This information could be useful for

its application in industrial fruit pickling, as well as relevant to the processing of other fruits and vegetables.

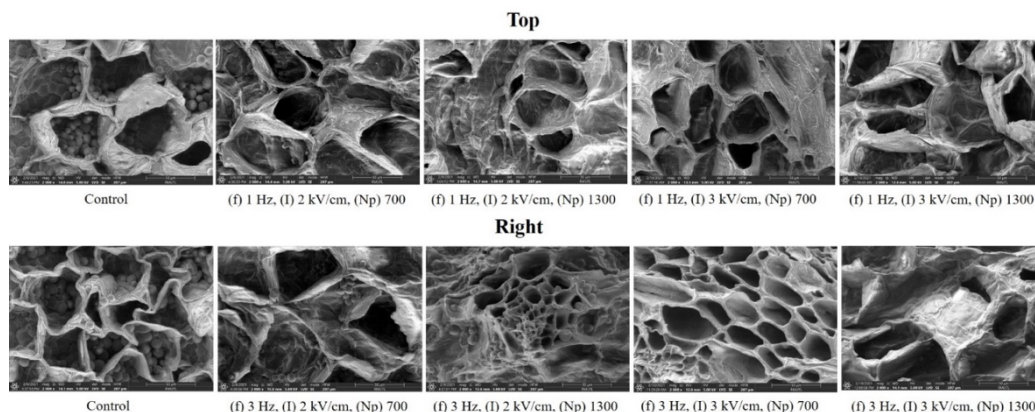

Fig. 6. SEM of untreated and PEF-treated mango samples.

Acknowledgements

The authors would like to thank the National Research Council of Thailand (NRCT) under the Royal Golden Jubilee Ph.D. Program (RGJ) Contract No. PHD/0092/2561 and National Research Council of Thailand (NRCT) Contract No. N42A650197 and the Thailand Science Research and Innovation Fundamental Fund (Grant no. 66082).

References

- [1] Jeni K, Yapa M, Rattanadecho P. Design and analysis of the commercialized drier processing using a combined unsymmetrical double-feed microwave and vacuum system (case study: tea leaves). *Chem Eng Process Intensif* 2010;49:389-95.
- [2] Barański M, Średnicka-Tober D, Volakakis N, Seal C, Sanderson R, Stewart GB, et al. Higher antioxidant and lower cadmium concentrations and lower incidence of pesticide residues in organically grown crops: a systematic literature review and meta-analyses. *Br J Nutr* 2014;112:794-811.
- [3] Dermesonlouoglou EK, Giannakourou M, Taoukis PS. Kinetic study of the effect of the osmotic dehydration pre-treatment with alternative osmotic solutes to the shelf life of frozen strawberry. *Food Bioprod Process* 2016;99:212-21.
- [4] Sankat CK, Castaigne F, Maharaj R. The air drying behaviour of fresh and osmotically dehydrated banana slices. *Int J Food Sci Technol* 1996;31:123-35.
- [5] Chandra S, Kumari D. Recent development in osmotic dehydration of fruit and vegetables: a review. *Crit Rev Food Sci Nutr* 2015;55:552-61.
- [6] Tedjo W, Taiwo KA, Eshtiaghi MN, Knorr D. Comparison of pretreatment methods on water and solid diffusion kinetics of osmotically dehydrated mangos. *J Food Eng* 2002;53:133-42.
- [7] Siemer C, Toepfl S, Heinz V. Mass transport improvement by PEF—Applications in the area of extraction and distillation. *Distill from Model to Appl* 2012:211-32.
- [8] Ade-Omowaye BIO, Rastogi NK, Angersbach A, Knorr D. Osmotic dehydration of bell peppers: influence of high intensity electric field pulses and elevated temperature treatment. *J Food Eng* 2002;54:35-43.

- [9] Verkman AS. Water permeability measurement in living cells and complex tissues. *J Membr Biol* 2000;173:73-87.
- [10] Dixon GM, Jen JJ. Changes of sugars and acids of osmovac-dried apple slices. *J Food Sci* 1977;42:1126-7.
- [11] Dermesonlouoglou E, Zachariou I, Andreou V, Taoukis PS. Effect of pulsed electric fields on mass transfer and quality of osmotically dehydrated kiwifruit. *Food Bioprod Process* 2016;100:535-44.
- [12] El-Aouar AA, Azoubel PM, Barbosa Jr JL, Murr FEX. Influence of the osmotic agent on the osmotic dehydration of papaya (*Carica papaya* L.). *J Food Eng* 2006;75:267-74.
- [13] AOAC. Official methods of analysis of AOAC International. AOAC International; 2005.
- [14] Taiwo KA, Angersbach A, Knorr D. Effects of pulsed electric field on quality factors and mass transfer during osmotic dehydration of apples. *J Food Process Eng* 2003;26:31-48.
- [15] Traffano-Schiffo MV, Laghi L, Castro-Giraldez M, Tylewicz U, Romani S, Ragni L, et al. Osmotic dehydration of organic kiwifruit pre-treated by pulsed electric fields: Internal transport and transformations analyzed by NMR. *Innov Food Sci Emerg Technol* 2017;41:259-66.
- [16] Amami E, Vorobiev E, Kechaou N. Modelling of mass transfer during osmotic dehydration of apple tissue pre-treated by pulsed electric field. *LWT-Food Sci Technol* 2006;39:1014-21.
- [17] Dellarosa N, Ragni L, Laghi L, Tylewicz U, Rocculi P, Dalla Rosa M. Time domain nuclear magnetic resonance to monitor mass transfer mechanisms in apple tissue promoted by osmotic dehydration combined with pulsed electric fields. *Innov Food Sci Emerg Technol* 2016;37:345-51.
- [18] Angersbach A, Heinz V, Knorr D. Evaluation of process-induced dimensional changes in the membrane structure of biological cells using impedance measurement. *Biotechnol Prog* 2002;18:597-603.
- [19] Wiktor A, Śledź M, Nowacka M, Chudoba T, Witrowa-Rajchert D. Pulsed electric field pretreatment for osmotic dehydration of apple tissue: experimental and mathematical modeling studies. *Dry Technol* 2014;32:408-17.
- [20] Mauro MA, Dellarosa N, Tylewicz U, Tappi S, Laghi L, Rocculi P, et al. Calcium and ascorbic acid affect cellular structure and water mobility in apple tissue during osmotic dehydration in sucrose solutions. *Food Chem* 2016;195:19-28.
- [21] Panarese V, Laghi L, Pisi A, Tylewicz U, Dalla Rosa M, Rocculi P. Effect of osmotic dehydration on *Actinidia deliciosa* kiwifruit: A combined NMR and ultrastructural study. *Food Chem* 2012;132:1706-12.
- [22] Tylewicz U, Tappi S, Mannozi C, Romani S, Dellarosa N, Laghi L, et al. Effect of pulsed electric field (PEF) pre-treatment coupled with osmotic dehydration on physico-chemical characteristics of organic strawberries. *J Food Eng* 2017;213:2-9.
- [23] Tylewicz U, Panarese V, Laghi L, Rocculi P, Nowacka M, Placucci G, et al. NMR and DSC water study during osmotic dehydration of *Actinidia deliciosa* and *Actinidia chinensis* kiwifruit. *Food Biophys* 2011;6:327-33.
- [24] Fincan M, Dejmek P. In situ visualization of the effect of a pulsed electric field on plant tissue. *J Food Eng* 2002;55:223-30.

- [25] Chiralt A, Talens P. Physical and chemical changes induced by osmotic dehydration in plant tissues. *J Food Eng* 2005;67:167-77.
- [26] Asavasanti S, Ristenpart W, Stroeve P, Barrett DM. Permeabilization of Plant Tissues by Monopolar Pulsed Electric Fields: Effect of Frequency. *J Food Sci* 2011;76:E98-111.
- [27] Thamkaew G, Galindo FG. Influence of pulsed and moderate electric field protocols on the reversible permeabilization and drying of Thai basil leaves. *Innov Food Sci Emerg Technol* 2020;64:102430.
- [28] Rastogi NK, Eshtiaghi MN, Knorr D. Accelerated mass transfer during osmotic dehydration of high intensity electrical field pulse pretreated carrots. *J Food Sci* 1999;64:1020-3.